

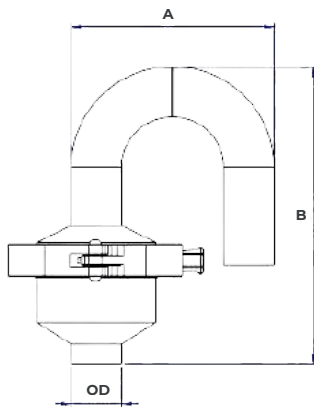

AIR RELEASE VALVE



Air Release Valve

INCH	OD	A	B
3/4"	19.05	115	158
1"	25.40	97	140

ITEM NO.	DESCRIPTION	MATERIAL	QTY
1	Hand Cover		1
2	Buttom		1
3	Seel		1
4	Ball		1

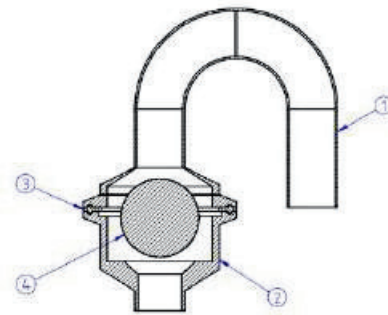

Product Application

: Air Release Valve
: Air release valve is designed to remove air from a process line without loss of product. The valve will not allow air to enter the line or container under vacuum. Air release valve is installed vertically ion the top of a pipeline or container, or before the inlet of a pump where air releasing is required.

Body Material

: Stainless Steel 316L made out from precision CNC milling machine

Ball Material

: Polypropylene (PP)

Seal Material

: EPDM

Working Pressure

: Maximum 10 bar

Working Temperature

: 90 degree C (due to the PP ball)

Product Density

: The specific gravity of the product liquid must be 1.0 or higher.

Size

: 3/4" , 1"

